

DIG Transfer Case Kit for BRX02-88 (#BRX02334)

Difficulty Level: ★★★★★

INSTALLATION MANUAL

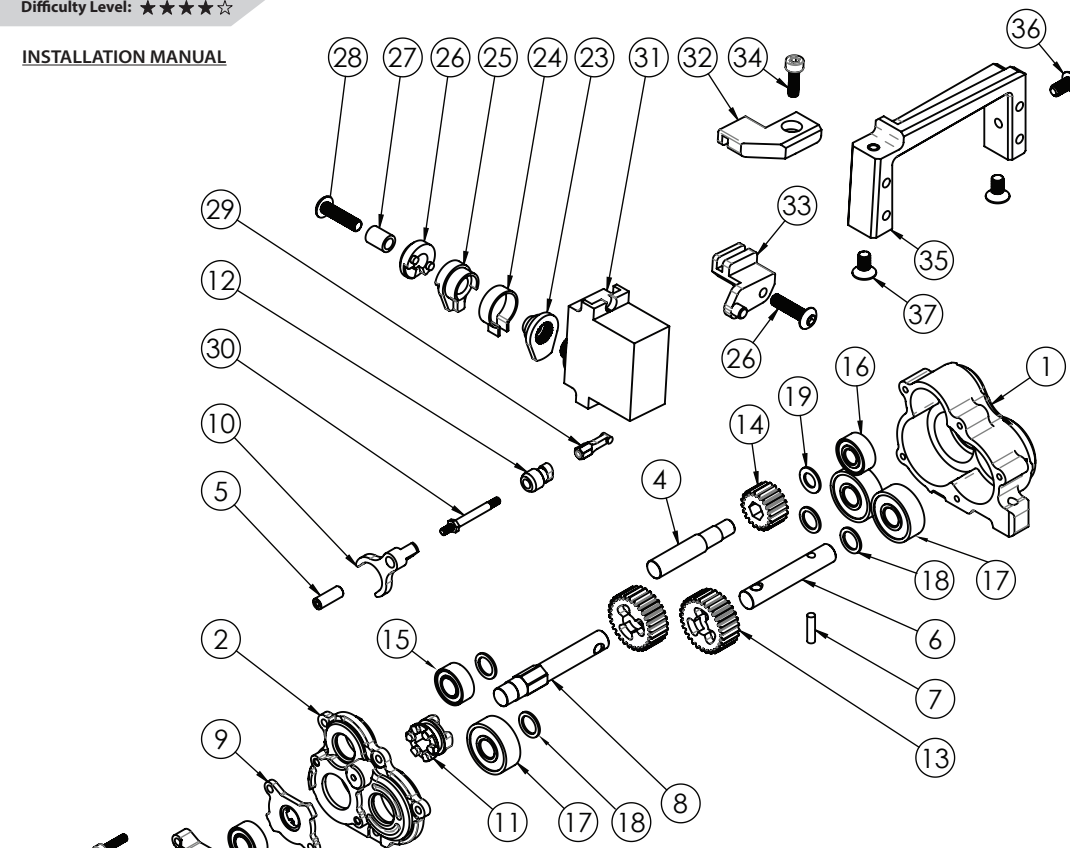

Parts Included:	Qty.
(1) T-Case Housing	1
(2) T-Case Cover	1
(3) T-Case Cap	1
(4) Guiding Shaft	1
(5) Guide	1
(6) Front Output Shaft #BRLC70101-B	1
(7) D2 x 8mm pin #BRASPIN210	1
(8) Rear Output Shaft #BRLC70101-C	1
(9) Catcher Guard	1
(10) Shift Fork	1

Parts Included:	Qty.
(11) Catcher	1
(12) Shift Rod Bushing	1
(13) 29T Spur Gear	2
(14) 20T Input Gear #BRLC70210	1
(15) D5 x 10 x 4 Bearing #BBZMR1052RS	2
(16) D4 x 10 x 4 Bearing #BBZMR1042RS	1
(17) D5 x 14 x 5 Bearing #BBZ6052RS	3
(18) D5 x 7 x 0.5 Spacer	4
(19) D4 x 7 x 0.5 Spacer	1
(20) M2 x 8 SC Screw	5
(21) M1.6 x 5 SC Screw #BRPROB-07	1
(22) M2x10 SC Screw #BRASCH1605	2
(23) Horn Initiator #BRASCH2010	1
(24) Tension Spring	1

Parts Included:	Qty.
(25) Horn Follower	1
(26) Follower Cap	2
(27) Follower Pivot Spacer	1
(28) M3 x 12 RC Screw #BRASBH3012	1
(29) T-Shape Grip	1
(30) Shift Rod	1
(31) JX Water Proof Servo #JX/PDI-HV1151MG	1
(32) Servo Top Bracket	1
(33) Servo Bottom Bracket	1
(34) M2.5x8 SC Screw #BRASCH2508	1
(35) Winch Mount	1
(36) M3 x 6 RS Screw	1
(37) M3 x 6 CSS Screw #BRASBH3006	2
(38) 16T Spur Gear	1
(39) 33T Spur Gear	1
(40) 25T Input Gear #BRLC70201-GEAR	1

T-Case Cover

1.

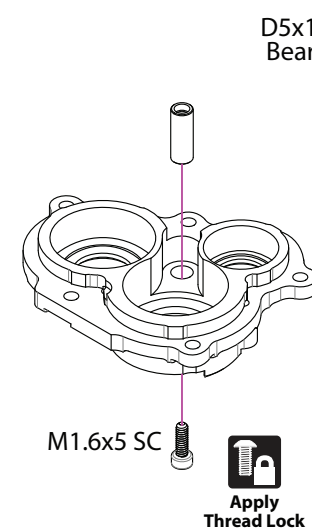

2.

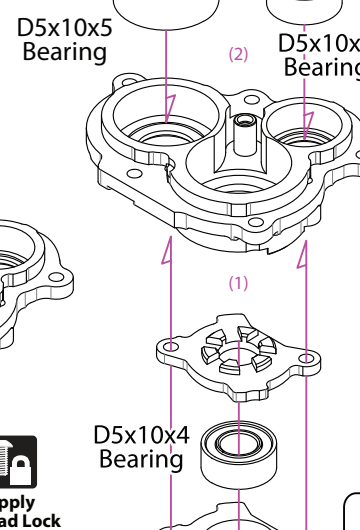

T-Case Housing

3.

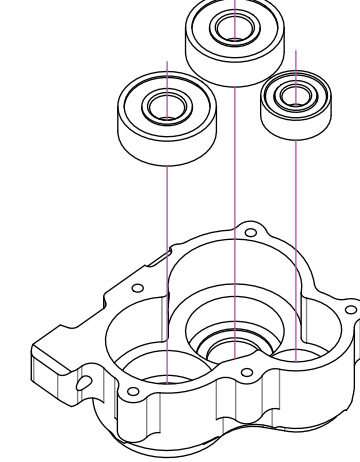

4.

Apply black grease on both spacers for sticking onto the input gear.

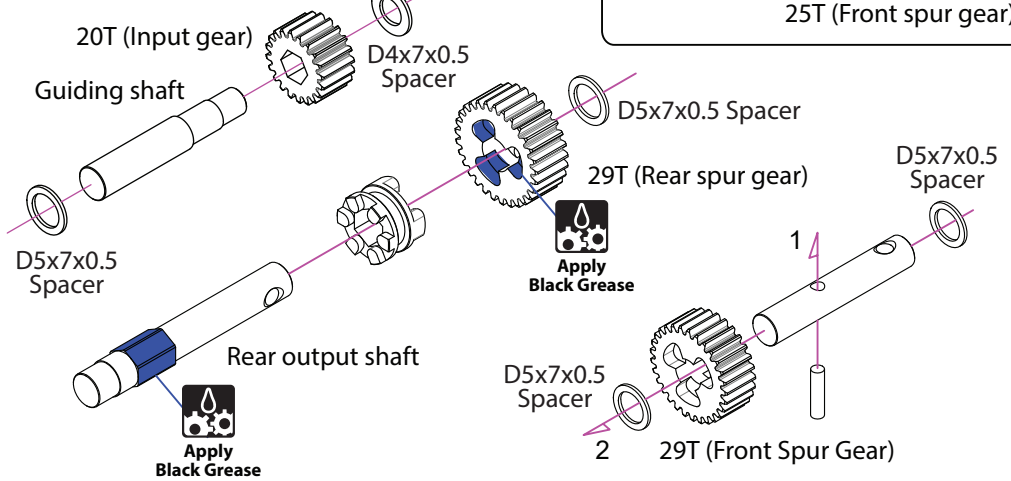

Optional overdrive gears set

16T (Input gear) (38)

33T (Rear spur gear) (39)

25T (Front spur gear) (40)

DIG Transfer Case Kit for BRX02-88 (#BRX02334)

Difficulty Level: ★★★★★

5.

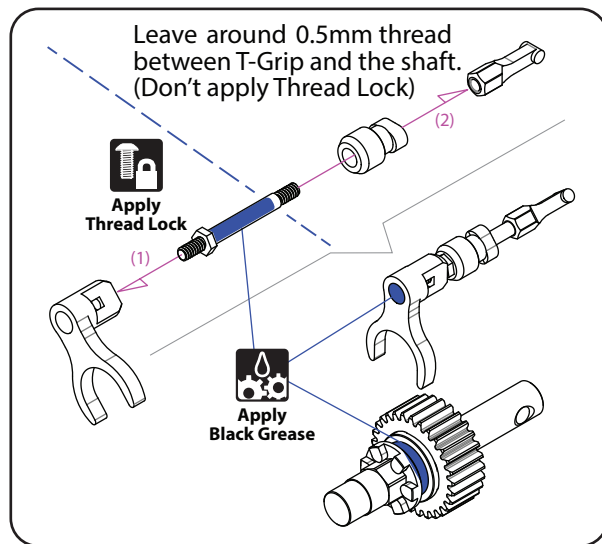

6.

Turn the Shift Rod Bushing clockwise to lock.

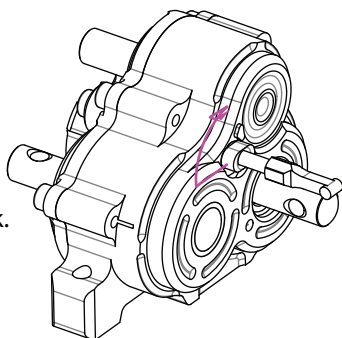

7.

Adjust the T-Grip clockwise to make the handle position horizontally.

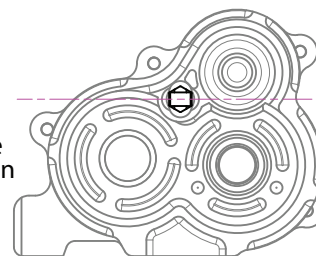

8.

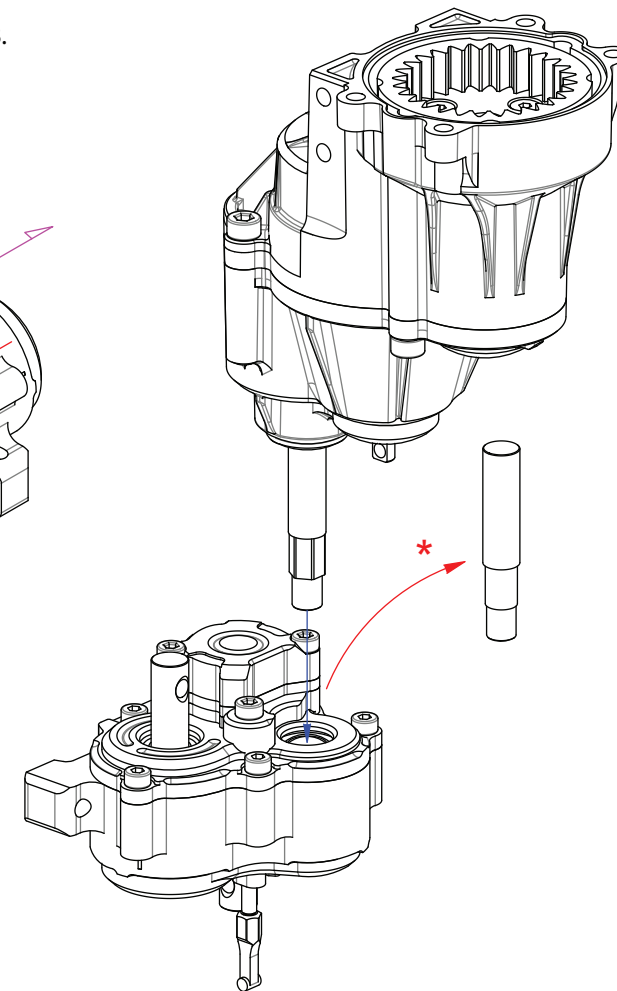

If the transmission on the chassis has been previously installed, detach the drive shafts and remove both the gearbox and the transfer case from the chassis.

Carefully remove the Guiding Shaft(*) in an upward direction to prevent misalignment between the spacers and the input gear inside the transfer case before engaging the new transfer case with the gearbox. Then proceed to re-install the unit onto the chassis.

DIG Transfer Case Kit for BRX02-88 (#BRX02334)

Difficulty Level: ★★★★★

9.

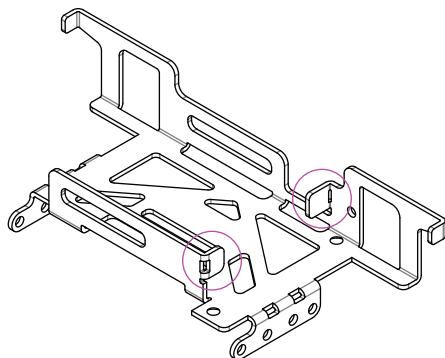

If the winch mount is not installed previously, detach the battery tray and bend inward both tabs indicated.

10.

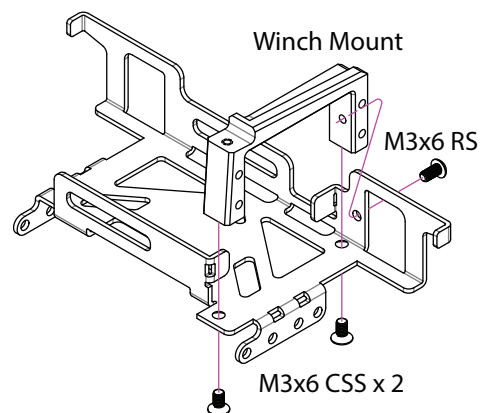

11.

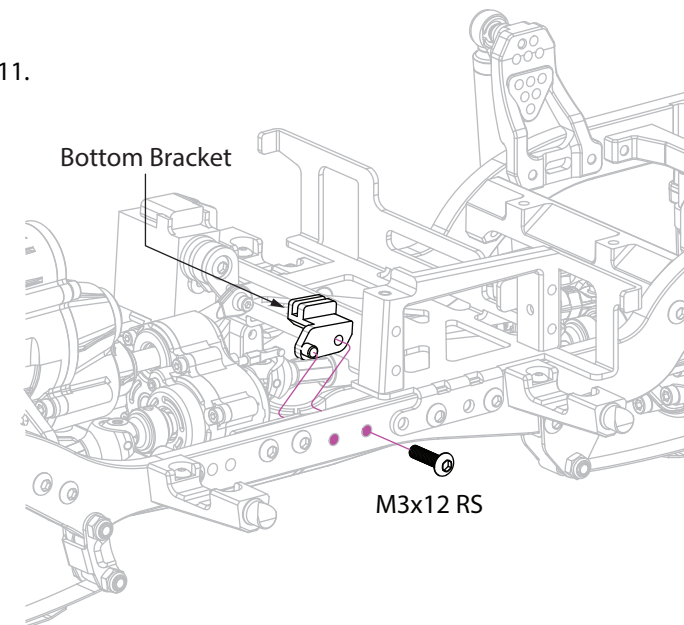

12.

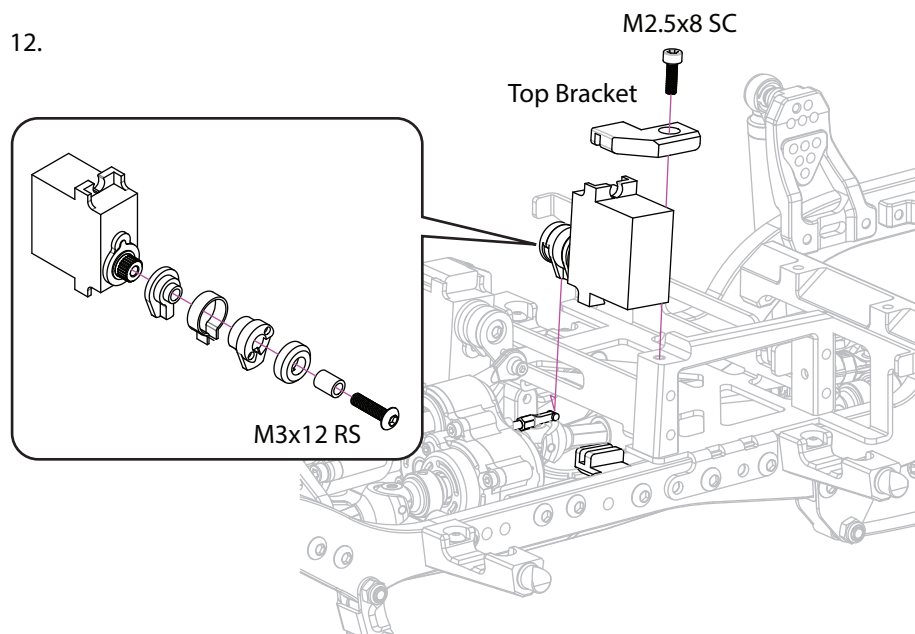

13.

